Effects of Direct and Indirect Cross-Group Friendships on Judgments of Catholics and Protestants in Northern Ireland: The Mediating Role of an Anxiety-Reduction Mechanism

Stefania Paolini

University of Newcastle, Australia

Miles Hewstone

University of Oxford, United Kingdom

Ed Cairns

University of Ulster, United Kingdom

Alberto Voci

University of Padova, Italy

Recent evidence suggests that both direct and indirect friendship with outgroup members (knowledge of ingroup members' friendship with outgroup members) can reduce prejudice toward the outgroup. Two surveys of cross-community relationships in Northern Ireland, using a student sample (N = 341) and a representative sample of the general population (N = 735), tested whether (a) direct and indirect friendships had generalized effects on both prejudice and perceived outgroup variability and (b) reduced anxiety about future encounters with outgroup members mediated such relationships. Structural equation modeling confirmed that, in both samples, direct and indirect cross-group friendships between Catholics and Protestants were associated with reduced prejudice toward the religious outgroup and increased perceived outgroup variability, via an anxiety-reduction mechanism. It is argued that emerging generalization hypotheses help to integrate both cognition and affect and interpersonal and intergroup approaches to contact.

Keywords: *friendship; anxiety; group variability; generalization; contact hypothesis*

Two new hypotheses for improving group relations in natural contact settings are currently receiving research attention. The so-called "direct cross-group friendship hypothesis" (Pettigrew, 1997) suggests that a reduction in group prejudice might be achieved by promoting direct friendship between members of rival groups. The

"indirect cross-group friendship hypothesis" (Wright, Aron, McLaughlin-Volpe, & Ropp, 1997) suggests that such a beneficial effect might also stem from "vicarious" experiences of friendship, that is, from the knowledge of ingroup members being friends with outgroup members.

Two surveys tested these two hypotheses in a setting characterized by a long, and continuing, history of animosity and intergroup conflict, namely, sectarianism between Catholics and Protestants in Northern Ireland. For the first time, research is carried out to test whether cross-group friendship can both reduce prejudice toward the outgroup and increase perceived outgroup variability, and an insight is offered into the underlying

Authors' Note: The research reported in this article was carried out as part of the first author's Ph.D., supervised by the second author. It was funded by a postgraduate research grant from the Economic and Social Research Council (R00429834600), a Ph.D. studentship from Cardiff's School of Psychology to the first author, and a grant from the Templeton Foundation to the second and third authors. We thank Gordon Harold for his encouragement with early data analysis, Frances McLernon for her help with data collection for Study 1, and Steve Wright and two anonymous reviewers for their invaluable comments on an early version of this article. Correspondence concerning this article should be addressed to Stefania Paolini, School of Behavioural Sciences, Psychology Building, University of Newcastle, Callaghan, NSW2308, Australia; e-mail: Stefania.Paolini@Newcastle.edu.au.

PSPB, Vol. 30 No. 6, June 2004 770-786

DOI: 10.1177/0146167203262848

© 2004 by the Society for Personality and Social Psychology, Inc.

psychological mechanism. We begin by looking at the theoretical context in which these hypotheses emerged.

THE INTERPERSONAL-INTERGROUP CONTROVERSY

Two theoretical approaches, both rooted in social identity theory (Tajfel & Turner, 1979), have derived competing predictions regarding the type of contact setting that should be most beneficial for reducing prejudice and ameliorating intergroup relations. Both approaches, the interpersonal (Brewer & Miller, 1984) and the intergroup (Hewstone & Brown, 1986), attribute a crucial role to category salience but they diverge sharply over the “recommended dose.” Brewer and Miller argue that to achieve harmonious intergroup relations, group membership needs to be made less salient:

The contact situation must be designed to eliminate or overcome the features that promote category salience. In effect, the situation must reduce information processing that is category-based and must promote, instead, attention to personal or individual information that is not correlated with category membership. (Brewer & Miller, 1988, p. 320)

Unfortunately, this model suffers a major social cognitive weakness. With individuating information about a categorized individual, perceivers should release the individual from the category and, in so doing, render the stereotype immune from the attributes of the specific group member (Rothbart & John, 1985, p. 92). Hence, the very conditions that promote reduced category salience impede generalization by weakening the cognitive link between the specific group member and his or her social category (Brewer & Miller, 1988; Hewstone & Brown, 1986; for evidence, see Scarberry, Ratcliff, Lord, Lanicek, & Desforges, 1997).

In contrast to the interpersonal approach, Hewstone and Brown’s (1986) intergroup approach argues that to ensure generalization, “ingroup members who have contact with outgroup members must, at some level, continue to be aware of the contact partner as a member of the outgroup and not simply a positive individual” (Van Oudenhoven, Groenewoud, & Hewstone, 1996, p. 658). Unfortunately, by making contact “intergroup,” especially when the salience of group memberships is very high, the interaction with group members may become characterized by anxiety, discomfort, and fear (Hewstone, 1996; Hewstone & Brown, 1986; Wright et al., 1997). High levels of intergroup anxiety may amplify normative behavioral patterns, cause cognitive and motivational information processing biases, intensify self-awareness, and augment emotional reactions (Stephan & Stephan, 1985; Wilder, 1993). These cognitive and behavioral responses would ultimately encour-

age individuals to avoid intergroup encounters and to react defensively and in an extreme manner to members of rival groups (Islam & Hewstone, 1993). Neither the interpersonal nor the intergroup approach alone offers an unequivocal solution to prejudice and conflictual intergroup relations: Interpersonal encounters would be pleasant but would be likely to fail to generalize, whereas intergroup encounters would generalize but would be likely to generate anxiety.

COMBINED APPROACHES

The theoretical tension between the interpersonal and the intergroup approaches (see, e.g., Brown, Vivian, & Hewstone, 1999; Pettigrew, 1998) has provided fertile territory for the conceptualization of both direct and indirect cross-group friendship hypotheses.

The Direct Cross-Group Friendship Hypothesis

Pettigrew (1997, 1998) tries to achieve integration between the interpersonal and the intergroup approaches to contact by gradually increasing category salience over time (see also Hewstone, 1996). Brewer and Miller’s (1984) interpersonal orientation would come first to increase the chance of liking between the contact partners; Hewstone and Brown’s (1986) salience of categorization would come next to reduce prejudice via generalization. The third step, aimed at maximizing the reduction in prejudice, would—in Pettigrew’s view—involve a recategorization process whereby partners of rival groups replace distinct identities with a common ingroup identity (Gaertner, Dovidio, Anastasio, Bachman, & Rust, 1993; Sherif, 1966) or, better still, adopt a “dual identity” of both subordinate and superordinate group identities (Gaertner & Dovidio, 2000).

Despite the merits of implementing this third stage, we believe that the most innovative element of Pettigrew’s (1997) conceptualization lies in the special role that, within his three-stage process, he attributes to cross-group friendship. Close interaction with an outgroup member, self-disclosure, extensive and repeated contact in a variety of social contexts, and other friendship-developing mechanisms are believed to provide the ideal ground for the three stages to unfold. Hence, according to the direct cross-group friendship hypothesis, to achieve generalization, “the contact situation must provide the participants with the opportunity to become friends” (Pettigrew, 1998, p. 76, emphasis removed).

The Indirect Cross-Group Friendship Hypothesis

Direct cross-group friendship might not be the only type of friendship to improve intergroup relations by promoting generalization of positive attitudes from an

individual group member to the outgroup as a whole. Wright and colleagues (1997) propose that knowing that ingroup members have a close relationship with outgroup members might also ameliorate group judgments. This effect of vicarious or indirect cross-group friendship is expected to occur because three elements serve as catalysts: the positivity and friendliness of the behaviors that the outgroup member exhibits (or is assumed to exhibit) toward the ingroup member; the referent informational influence of the ingroup member, demonstrating positive intergroup attitudes and tolerant ingroup norms (Haslam, McGarty, & Turner, 1996; Liebkind, & McAlister, 1999); and the cognitive inclusion of the ingroup and outgroup members in the self (E. R. Smith & Henry, 1996).

Wright and colleagues (1997) believe indirect friendship to have even greater potential for achieving harmonious intergroup relations than direct friendship for three reasons. First, because group membership is expected to be relatively more salient—thus facilitating generalization—to an observer not acquainted with the individuating features of the outgroup member than to the individual directly involved in the cross-group friendship. Second, because intergroup anxiety should be weaker in vicarious experiences than in firsthand experiences, thus reducing the risk of undesired correlates of anxiety typical of intergroup encounters. Third, because indirect friendship can improve intergroup relations without every group member having to have intergroup friends themselves, thus being easier to implement on a larger scale.

PREVIOUS RESEARCH ON CROSS-GROUP FRIENDSHIP

Allport (1954) and Amir (1976) emphasized the importance of intimacy in intergroup contact, yet evidence concerning the relationship between direct cross-group friendship and group judgments is scattered (Hallinan, 1982; Hallinan & Teixeira, 1987; Jackman & Crane, 1986; Patchen, 1983). Cross-racial friendships, especially among children, have generally positive effects, although these effects are more likely for those already living in a neighborhood, or attending a school, with other-race children (DuBois & Hirsch, 1990; Ellison & Powers, 1994; Phinney, Ferguson, & Tate, 1997). For example, Oliner and Oliner (1988) found that non-Jewish individuals who risked their lives to save Jews during World War II reported having more close friendships with members of other groups when they were children than did non-Jewish individuals who did not engage in rescue efforts. In a two-wave telephone survey, Herek and Capitanio (1996) found that respondents who had a close friend disclosing his or her homosexuality to them held more positive attitudes toward gay people in general than did other respondents. Pettigrew (1997)

reported the most extensive test of the direct cross-group friendship hypothesis (see Hamberger & Hewstone, 1997, for different analyses of the same data). His correlational study investigated the effect of friendship with members of social minorities among 3,800 members of the dominant national group in France, United Kingdom, the Netherlands, and West Germany. Consistent with Pettigrew's hypothesis, an increase in cross-group friendship predicted a significant reduction in prejudice toward social minorities (this effect was significantly stronger than the reverse one; i.e., increased prejudice leading to friendship avoidance). All this evidence indicates that direct cross-group friendship might be related to more benevolent group judgments.

Some prior research also can be reinterpreted in light of the indirect cross-group friendship hypothesis. In a longitudinal study by Hamilton and Bishop (1976), White respondents reported reduced prejudice toward Black people when a Black family arrived in their previously racially homogeneous neighborhood. What is relevant here (see Wright et al., 1997) is that this effect occurred even when respondents did not report having had direct contact with the Black family, hence suggesting that vicarious contact might be as beneficial as face-to-face contact. The most extensive test of the indirect cross-group friendship hypothesis, however, was provided by Wright and colleagues. In two correlational investigations, respondents—belonging to either majority or minority groups—who knew at least one ingroup member with an outgroup friend consistently reported weaker outgroup prejudice than did respondents without indirect friends; furthermore, the more ingroupers known to have friends in the outgroup, the weaker the prejudice. Wright et al. found a similar pattern of results in two experiments, a minimal group experiment and a 1-day simulation experiment. More recently, in a quasi-experimental field study, Liebkind and McAlister (1999) found that Finnish teenagers exposed to printed stories depicting cross-group friendship showed an increase or stability in tolerance for foreigners; attitudes worsened or stayed the same in teenagers not exposed to the cross-group friendship stories. Overall, this evidence clearly demonstrates that indirect friendship might generalize to more benevolent group evaluations.

LIMITATIONS OF PREVIOUS RESEARCH

By looking at the specific case of friend-to-group generalization, cross-group friendship research offers new conceptual tools for understanding the process of contact generalization and for discovering its underlying mechanisms. In so doing, it ultimately strengthens hopes of improving intergroup relations. Although promising, however, previous findings leave two fundamental questions unanswered. First, is it only prejudice

toward the outgroup that benefits from cross-group friendship experiences, or are other facets of the group judgment also sensitive to friendship generalization effects? Second, what is the psychological mechanism that is responsible for the beneficial impact of cross-group friendship? Are direct and indirect friendships governed by a common process, or do different types of cross-group friendship imply different processes?

Nature of the Group Judgment

Cross-group friendship researchers have concentrated their attention on prejudice and affect-based outcomes of contact (e.g., blatant and subtle prejudice, feelings, and attitudes toward immigration policies). However, a growing number of models of stereotyping now suggest that people also take into account the variability of group members when they mentally represent social groups (see, e.g., Kraus, Ryan, Judd, Hastie, & Park, 1993; Linville, 1998). Experimental evidence suggests that perceived outgroup variability plays an important role in a variety of intergroup phenomena and, once increased, may lead to less stereotyped intergroup relations via a variety of cognitive mechanisms. For example, increased outgroup variability increases the cognitive inclusion of deviant group members in the group representation (Lambert, 1987) and reduces the memory advantage for stereotype-congruent information (Pendry & Macrae, 1999), thus making group representations more susceptible to change. Moreover, increased outgroup variability increases the amount of information searched for when developing impressions of individual outgroup members (Ryan, Bogart, & Vender, 2000) and decreases the confidence in judging them on the sole basis of group information (Ryan, Judd, & Park, 1996), thus making cross-group interactions progressively less category based. Perceived outgroup variability is also affected, as the outcome variable, by important dimensions of the intergroup encounter, such as exposure to stereotype-incongruent information (Hewstone & Hamberger, 2000), threat to the ingroup (Rubin, Hewstone, & Voci, 2001), and need for assimilation and differentiation (Pickett & Brewer, 2001).

Previous research has shown a positive association between outgroup contact and perceived outgroup variability (Islam & Hewstone, 1993; Paolini, 2001; Stangor, Jonas, Stroebe, & Hewstone, 1996). There is an increase in variability when people generalize information from one (Garcia-Marques & Mackie, 1999, Study 2; Paolini, Hewstone, Rubin, & Pay, in press) or several (Garcia-Marques & Mackie, 1999, Studies 1 & 3; Hewstone & Hamberger, 2000, Study 2) individual outgroup members to the group as a whole. No previous research, however, has related cross-group friendship to group vari-

ability. But because direct and indirect outgroup friends are only special cases of outgroup members, it is reasonable to expect a similar process of information generalization to occur when people are faced with information about outgroup friends. To test this effect, in this research, as well as measuring prejudice as a criterion variable, we included a general measure of perceived outgroup variability (Kashima & Kashima, 1993). We hypothesized that direct and indirect cross-group friendships would predict a significant reduction in outgroup prejudice and a significant increase in perceived outgroup variability.

Nature of the Underlying Mechanism

Provided that friendship-to-group generalization effects do hold, the issue is *how* or *why* being friends with an outgroup member and knowing of ingroup friends who are friends with outgroup members would affect group judgments. To our knowledge, no potential mediators of friendship effects have yet been tested and identified. In our study, we assessed the role that an anxiety-reduction mechanism might play in cross-group friendship effects. Stephan and Stephan (1985) argued that people are likely to feel anxious when approaching encounters with members of different social groups because they hold a series of negative expectations. These individuals may fear embarrassment or frustration due to their own or others' incompetent or offensive behavior. They may fear rejection, discrimination, ridicule, or simply misunderstanding.

We believe that direct and indirect cross-group friendship may ameliorate group judgments by directly reducing this "intergroup anxiety." Friends, in fact, make us feel good and comfortable. Their closeness is associated with reduced generalized anxiety (Prinstein, Boergers, Spirito, Little, & Grapentine, 2000), social anxiety (La Greca & Lopez, 1998), state anxiety (Matsuzaki, Kojo, & Tanaka, 1993), and negative affective reactions to close interpersonal distance from another (Ashton, Shaw, & Worsham, 1980). Hence, if friendship functions as a general stress-buffering mechanism (Cohen, Sherrod, & Clark, 1986), then having outgroup friends may be likely to reduce the anxiety people experience during intergroup encounters. It may reduce fear of social gaffes, rejection, and uneasiness and, hence, have a generalized positive impact on people's reactions toward the outgroup. The same mechanism might also explain the effect of indirect friendship. Wright and colleagues (1997) share our belief:

Observing the ingroup partner's interactions and apparent attitudes may also reduce the observer's anxiety about the possibility of intergroup interaction . . . comfortable interaction demonstrated by the ingroup friend

may serve to reduce fear and negative expectation in the observer, leading to a more positive impression of the outgroup. (p. 75)

An anxiety-reduction mechanism might also mediate the relationship between cross-group friendship and perceived outgroup variability. Intergroup anxiety has already been found to mediate the positive relationship between contact and perceived outgroup variability (Islam & Hewstone, 1993); this finding has been interpreted as due to reduced anxiety broadening people's focus of attention (Eastbrook, 1959). This research first tested whether intergroup anxiety provides a common explanatory basis for both direct and indirect cross-group friendship effects on prejudice and perceived variability.

THE PRESENT RESEARCH

The aims of this research were to explore whether (a) direct and indirect cross-group friendship predicts reduced prejudice and increased perceived outgroup variability toward a rival group and whether (b) intergroup anxiety mediates such friendship-to-group relationships. Using two cross-sectional surveys, we investigated these issues in the context of Catholic-Protestant intergroup contact in Northern Ireland. This small province has a history of intergroup conflict lasting more than 300 years. This conflict involves the Protestant community, with a majority wishing for the province to remain part of the United Kingdom, and the Catholic community, with a majority wishing to see the unification of the island of Ireland (Cairns & Darby, 1998). Religious polarization in Northern Ireland is so strong that almost every aspect of life (e.g., streets, schools, shops, sports clubs) can be identified as either Catholic or Protestant (Trew, 1986). Unlike other well-known intergroup conflicts (see, e.g., Pettigrew, 1997; Wright et al., 1997), the conflict in Northern Ireland takes place between two relatively equal-sized groups, both capable of maintaining their own political, social, cultural, and educational infrastructure. The modern form of the conflict, known colloquially as "The Troubles," dates from 1969 until 1994, when the first declaration of peace or "ceasefire" was agreed (Jackson, 1999). The armed guerrilla warfare started again in 1996, but after 1 year another ceasefire was announced that still holds, albeit imperfectly, today.

The Troubles have led to more than 3,600 deaths and many thousands of serious injuries. Many citizens, who suffered directly or indirectly because of The Troubles, report psychological maladjustment (Hayes & Campbell, 2000; Muldoon & Trew, 2000). For others, experience of violence has fueled support for paramilitary organizations and further exacerbated the conflict (Hayes & McAllister, 2002). Despite the recent

ceasefires, Northern Ireland still has not achieved "normal" political and social stability and remains a deeply segregated society, especially in terms of education, residential location, and cross-community marriages (see Cairns & Hewstone, in press). Because of the diffuse impact of the conflict on the life of ordinary people, Northern Ireland is a severe testing ground for the hypothesized effects of cross-group friendship on intergroup evaluations.

STUDY 1

This first survey measured the number of direct and indirect cross-group friendships (predictor variables) that a sample of Catholic and Protestant students at the University of Ulster had with members of the rival community, intergroup anxiety (mediator variable), their prejudice toward the other community, and the degree of perceived outgroup variability (criterion variables). To ascertain the severity of the conflict and the degree to which it touches the lives of ordinary people, respondents were also surveyed for their experience of The Troubles.¹ The cross-group friendship effects and the mediational role of intergroup anxiety were tested by using structural equation modeling (Jöreskog & Sörbom, 1999).

Method

RESPONDENTS

Respondents were 341 students at three campuses of the University of Ulster, located in a large city in the East of the province, a small city in the West, and a rural area of the North. The sample comprised 148 men and 190 women (3 respondents did not report their gender); their mean age was 23.13 years ($SD = 5.80$). Respondents identified themselves as belonging to one of the two religious communities (Catholic community, 178; Protestant community, 163). Eighty-six percent reported having lived in Northern Ireland all of their lives, and 61% of the remainder reported having lived there for more than 10 years. Data were collected during the summer semester of 1999. The sample excludes 56 respondents who failed to complete the measure of indirect friendship.

PROCEDURE

A female investigator approached all of the potential respondents she happened to encounter around the University campus and invited them to take part in a study looking at the relations between Catholic and Protestant communities in Northern Ireland. The investigation was explicitly presented as carried out by the University's "Centre for the Study of Conflict." If willing to participate, the investigator handed them a questionnaire, together with an envelope, so that they could seal

the questionnaire before returning it. Respondents completed their questionnaire in private; however, the investigator remained nearby to provide assistance if required.

QUESTIONNAIRE

Predictor variables. Two items assessed direct cross-group friendship. Respondents were asked to rate the number of close friends they had who belonged to the other community (a) at home and (b) at the University (both items, 0 = 0, 1 = 1, 2 = 2 to 5, 3 = 5 to 10, 4 = more than 10). The two items were averaged to form a reliable index ($\alpha = .70$); higher scores indicate more outgroup friends. In contrast to the case for direct friendship (see Hewstone et al., in press), there were no prior or pilot data from this population on which to base the specific item response format for a measure of indirect friendship. Therefore, we used an open index of indirect cross-group friendship: Respondents indicated the number of friends belonging to their own community who had close friends from the other community.

Mediator variable. We used Stephan and Stephan's (1984) intergroup anxiety scale and adapted it to the Northern Irish intergroup setting. Respondents read the following:

We would like to ask you now about how you would feel in Northern Ireland mixing socially with complete strangers who were members of the other community. It doesn't matter whether you personally have very little or no contact with members of the other community; please try to imagine how you would feel. If you were the only person from your community and you found yourself with a group of people from the other community, how would you feel compared to an occasion where you found yourself with people of only your community?

Respondents rated the extent to which they would feel happy, awkward, self-conscious, confident, relaxed, and defensive (all scales, 0 = not at all, 1 = a little, 2 = some, 3 = quite, 4 = extremely). A reliable index was created ($\alpha = .90$) by first reversing the items happy, confident, and relaxed and then averaging all items together. Higher scores indicate higher intergroup anxiety.

Criterion variables. Seven items tapped prejudice toward the religious outgroup. Respondents were first asked to indicate their overall feeling toward the other community by marking an "X" anywhere along a "feeling thermometer" (0 = extremely unfavorable, 10 = very, 20 = quite, 30 = fairly, 40 = slightly, 50 = neither favorable nor unfavorable, 60 = slightly, 70 = fairly, 80 = quite, 90 = very, 100 = extremely favorable; see, e.g., Haddock, Zanna, & Esses, 1993). They were then asked to complete six bipolar scales (0 = warm, 4 = cold; 0 = negative, 4 = positive; 0 = friendly, 4 = hostile; 0 = suspicious, 4 = trusting; 0 = respect, 4 =

contempt; 0 = admiration, 4 = disgust; Wright et al., 1997). Scores from the feeling thermometer were first reversed and linearly transformed to equate their metric to the metric of the other items. The "positive" and "trusting" items were then reversed and averaged with all the other items into a reliable index ($\alpha = .91$) so that higher scores denote higher outgroup prejudice.

Three items tapped a general measure of perceived outgroup variability (Kashima & Kashima, 1993). Respondents rated the extent to which, in the other community, there were many different types of people (0 = not at all, 4 = extremely), the members were similar to each other (0 = not at all, 4 = extremely), and they were pretty much alike (0 = They're all completely different from one another, 4 = They're pretty much alike). The second and third items were first reversed, and then all the items were averaged to yield a reliable index ($\alpha = .73$); higher scores indicate higher perceived outgroup variability.

Sociodemographic variables. Finally, respondents were asked their age, gender, the time they lived in Northern Ireland (0 = less than 1 yr, 1 = 1 to 5 yrs, 2 = 5 to 10 yrs, 3 = more than 10 yrs, 4 = all my life) and whether they had had direct experience (i.e., personal experience) and indirect experience (i.e., experience of a relative or close friend) of moving house because of intimidation, of damage to their home by a bomb, and of injuries by a sectarian incident (yes, no). Religious affiliation was also coded using a standard measure in Northern Ireland. Respondents put a tick alongside one of the following denominations: Christian (no denomination); Church of Ireland/Anglican; Baptist; Methodist; Presbyterian; Free Presbyterian; Brethren; Other Protestant (please specify); Roman Catholic; Other non-Christian (please specify). Respondents were coded as being Protestant if they ticked any of the first 8 options, Catholic if they ticked the 9th option, and excluded if they ticked the 10th option.

Results and Discussion

PRELIMINARY ANALYSES

The items assessing the respondents' experience of The Troubles provided strong support for a high impact of the intercommunity conflict on the recruited respondents: Sixty-nine percent of the overall sample reported at least some direct or indirect experience of The Troubles. More specifically, 9.70% reported direct and 32% indirect experience of moving house because of intimidation; 12% reported direct and 37.50% indirect experience of damage to their home by a bomb; and 12.90% reported direct and 55.70% indirect experience of injuries by a sectarian incident. On average, respondents reported having between 2 and 10 outgroup friends ($M = 2.45$, $SD = 1.17$, $Skew = -.45$, $SE Skew = .13$, $Kurt = -.65$, SE

$Kurt = .26$) and approximately 9 indirect outgroup friends ($M = 9.39$, $SD = 11.39$, $Skew = 4.18$, $Kurt = 25.44$). The distribution of scores for indirect friendship was successfully normalized by using a logarithmic transformation ($Skew = -.28$, $Kurt = .29$). Respondents scored around the scale midpoint on the measures of intergroup anxiety ($M = 1.77$, $SD = 1.02$, $Skew = .21$, $Kurt = -.70$), prejudice ($M = 1.74$, $SD = .84$, $Skew = .084$, $Kurt = .06$), and perceived outgroup variability ($M = 2.15$, $SD = .94$, $Skew = .02$, $Kurt = -.49$).

Group comparisons. Table 1 contains the descriptives for all sociodemographic variables and variables included in the estimated model separately for Catholic and Protestant respondents. Subscripts identify significant differences between samples. We treat Catholic and Protestant samples together in all the analyses that follow because, despite the existence of some significant differences between groups, the two samples showed identical patterns of correlations between the variables included in the model.

STRUCTURAL EQUATION MODELING

We tested a causal model with latent variables using the maximum likelihood estimation method (LISREL 8.3, Jöreskog & Sörbom, 1999; Loehlin, 1998). Direct and indirect friendships were entered as predictor variables, intergroup anxiety as a mediator variable, and outgroup prejudice and perceived outgroup variability as criterion variables. The relationships between cross-group friendship and outgroup judgments were studied as direct effects and as indirect effects mediated by intergroup anxiety. To smooth measurement error and maintain an adequate ratio of cases to parameters, a partial disaggregation approach was adopted (Bagozzi & Heatherton, 1994; Hoyle, 1995). Thus, for each of the constructs, except for indirect friendship, we averaged items into subsets or parcel variables. The number of subsets used was one for direct friendship, three for intergroup anxiety and prejudice, and two for perceived outgroup variability.

The estimated model is represented in the path diagram depicted in Figure 1. We assessed the model's goodness of fit by using the chi-square test, the Comparative Fit Index (CFI), the root mean square of approximation (RMSEA), and the standardized root mean square residual (SRMR). A satisfactory fit is indicated by a nonsignificant chi-square or a chi-square lower than double the degrees of freedom (significant chi-squares are acceptable when the sample size is large as in the present research; see Carmines & McIver, 1981), a CFI value greater than .95, and values of RMSEA and SRMR less than .06 and .08, respectively (see Hu & Bentler, 1999). Our theoretical model provided good fit to the data, $\chi^2(27, N = 341) = 49.48$, $p > .005$; CFI = .99; RMSEA =

TABLE 1: Descriptives of Sociodemographic Variables and Variables Included in the Model for Catholic and Protestant Respondents (Study 1)

Variable	Catholic (n = 178)	Protestant (n = 163)
Sociodemographic variables ^a		
Age		
M	22.22 _a	24.14 _b
SD	4.49	6.84
Male	44.40 _a	42.30 _a
Lived in Northern Ireland all life	87.10 _a	84.00 _a
Moving house because of intimidation	12.90 _a	6.10 _b
Having house damaged by a bomb	12.90 _a	11.00 _a
Being injured due to a sectarian incident	17.40 _a	8.00 _b
Relative or close friend moving house because of intimidation	42.70 _a	20.20 _b
Relative or close friend having house damaged by a bomb	39.30 _a	35.80 _a
Relative or close friend being injured due to a sectarian incident	65.20 _a	45.40 _b
Variables included in the model ^b		
Direct friendship		
M	2.33 _a	2.58 _b
SD	1.22	1.13
Indirect friendship		
M	8.93 _a	9.89 _a
SD	10.45	12.35
Intergroup anxiety		
M	1.91 _a	1.63 _b
SD	1.00	1.03
Outgroup prejudice		
M	1.81 _a	1.66 _a
SD	0.69	0.98
Perceived outgroup variability		
M	2.14 _a	2.15 _a
SD	0.93	0.94

NOTE: Means and frequencies with different subscripts differ significantly at $p < .05$.

a. All sociodemographic indices, except for age (number of years), are percentages.

b. All indices included in the model, except for indirect friendship (number of indirect friends), range between 0 and 4.

.049; SRMR = .023. The model accounted for 27% of the variance in anxiety, for 54% of the variance in outgroup prejudice, and for a more modest portion in perceived outgroup variability (17%).

Previous studies (Hamberger & Hewstone, 1997; Pettigrew, 1997) demonstrated that outgroup friendship significantly predicts improved outgroup attitudes. In this research, we expected the number of direct cross-group friendship to predict both a significant reduction in prejudice and a significant increase in perceived outgroup variability. Both predictions were supported. Direct cross-group friendship had a direct negative effect on prejudice (standardized, $\beta = -.19$, unstandardized, $b = -.17$, $p < .01$); moreover, it affected perceived variability, but only indirectly, mediated by intergroup anxiety, which was negatively associated with perceived

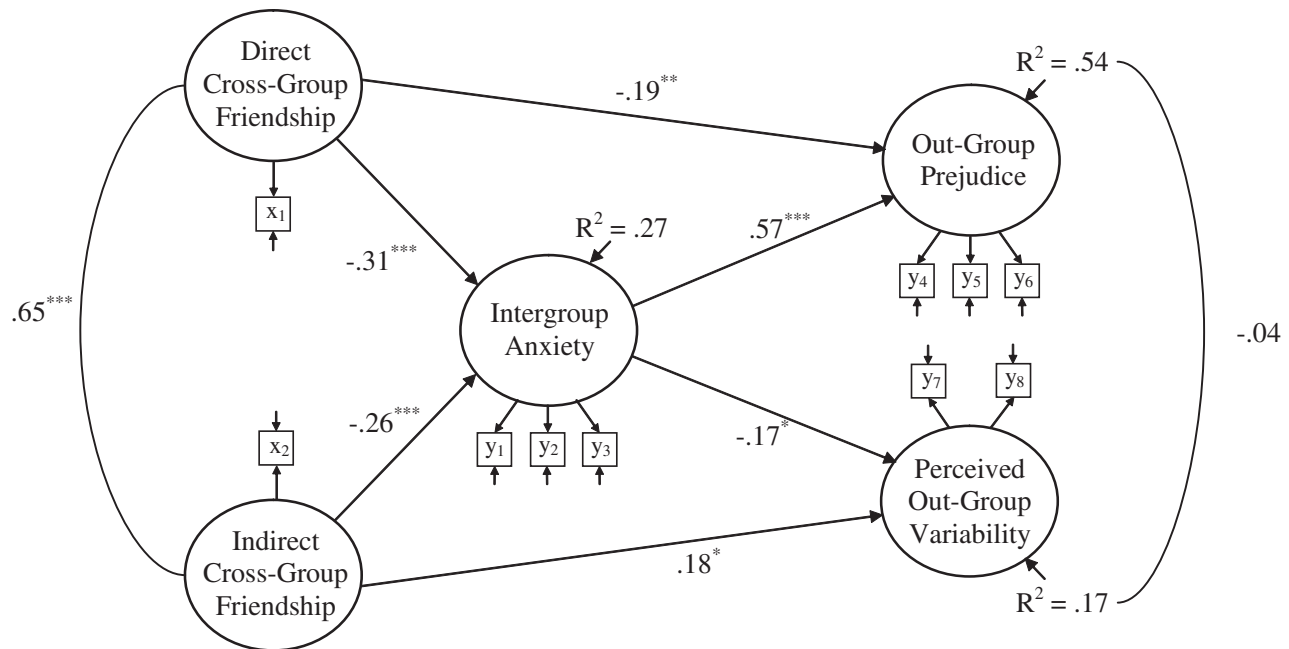

Figure 1 Estimated model of direct and indirect cross-group friendship for university students sample in Study 1.

NOTE: Values are standardized beta weights. $\chi^2(27, N=341) = 49.48, p > .005$, Comparative Fit Index (CFI) = .99, root mean square error of approximation (RMSEA) = .049, standardized root mean square residual (SRMR) = .023.

* $p < .05$. ** $p < .01$. *** $p < .001$.

variability ($\beta = -.17, b = -.16, p < .05$). Wright and colleagues (1997) found that the number of indirect outgroup friends significantly predicted improved outgroup attitudes. In this study, we expected indirect friendship to be significantly related to both outgroup prejudice and perceived outgroup variability. As predicted, indirect cross-group friendship significantly affected prejudice, but only indirectly, mediated by intergroup anxiety, which was strongly associated with prejudice ($\beta = .57, b = .54, p < .001$); moreover, indirect cross-group friendship had a direct and positive effect on perceived variability ($\beta = .18, b = .16, p < .05$). Thus, direct and indirect cross-group friendship predicted both reduced prejudice and increased group variability toward the rival group.

Finally, we expected intergroup anxiety to function as a mediator of the effects exerted by both direct and indirect friendship on group judgments. Direct and indirect cross-group friendships were negatively related to intergroup anxiety ($\beta = -.31, b = -.30, p < .001$; $\beta = -.26, b = -.25, p < .001$, respectively). The direct paths linking direct cross-group friendship to outgroup variability and indirect friendship to prejudice were not reliable ($\beta = .14, b = .13, p > .05$; $\beta = -.09, b = -.09, p > .05$, respectively), suggesting that both the relationship between direct friendship and group variability and the relationship between indirect friendship and prejudice were fully

mediated by intergroup anxiety. Partial mediation of anxiety held for the relationship between direct friendship and prejudice and between indirect friendship and perceived variability. No noticeable association was found between the two outcome variables, $r = -.04, p > .05$.

EFFECTS DECOMPOSITION

To assess the overall effect exerted by each factor on the criterion variables and the strength of the mediation effects, we carried out an effects decomposition of the correlations between each pair of variables (Loehlin, 1998). A summary of this analysis is shown in Table 2. The total effect (TE) of direct friendship on prejudice (TE = $-.37, p < .001$) seemed greater than the total effect of indirect friendship (TE = $-.24, p < .001$). No such difference was evident for perceived outgroup variability (direct friendship, TE = $.20, p < .05$; indirect friendship, TE = $.23, p < .01$). More importantly, the indirect effect (IE) that each predictor variable exerted on each of the criterion variables was also significant, although sometimes quite modest in size (direct friendship-to-prejudice, IE = $-.18, p < .001$; direct friendship-to-variability, IE = $.05, p < .05$; indirect friendship-to-prejudice, IE = $-.15, p < .001$; indirect friendship-to-variability, IE = $.05, p < .05$), confirming that each type of cross-group friendship played a significant role in predicting each type of group judgment and that intergroup anxiety was a significant

TABLE 2: Intercorrelations for all Variables and Effects Decomposition (Study 1)

Bivariate Relationship		Total Correlation	Causal Effects			
Predictor	Criterion		DE	IE	TE	
Direct friendship	Intergroup anxiety	-.48***	-.31*** (-.30)	—	-.31*** (-.30)	
Indirect friendship	Intergroup anxiety	-.45***	-.26*** (-.25)	—	-.26*** (-.25)	
Direct friendship	Outgroup prejudice	-.53***	-.19** (-.17)	-.18*** (-.16)	-.37*** (-.34)	
Indirect friendship	Outgroup prejudice	-.48***	-.09 (-.09)	-.15*** (-.14)	-.24*** (-.22)	
Intergroup anxiety	Outgroup prejudice	.68***	.57*** (.54)	—	.57*** (.54)	
Direct friendship	Perceived variability	.36***	.14 (.13)	.05* (.05)	.20* (.17)	
Indirect friendship	Perceived variability	.38***	.18* (.16)	.05* (.04)	.23** (.20)	
Intergroup anxiety	Perceived variability	-.35***	-.17* (-.16)	—	-.17* (-.16)	

NOTE: $N = 341$. DE = direct effect; IE = indirect effect; TE = total effect. Unstandardized effects are in parentheses.

* $p < .05$. ** $p < .01$. *** $p < .001$.

mediator of both the direct and indirect friendship-to-group relationships.

STUDY 2

Study 1 confirms that, at least among Catholic and Protestant students, direct (Pettigrew, 1997) and indirect (Wright et al., 1997) cross-group friendship predict both reduction in outgroup prejudice and increase in perceived outgroup variability and that both cross-group friendship effects are, at least partly, mediated by an anxiety-reduction mechanism. Although Study 1 did not employ a probabilistic sample, because it gathered data from three different campuses of the University of Ulster (which caters to students of diverse social backgrounds and is located in different areas of the province), we were reasonably confident that its results could, at least, adequately generalize to the university student population of Northern Ireland. Unfortunately, we could not be equally confident that they extended to the general adult population of the province.

Cross-community experiences of university students in Northern Ireland are likely to differ from those of the general population in several important respects. First, higher levels of education are generally associated with less virulent outgroup attitudes (Pettigrew et al., 1998), specifically in Northern Ireland (see Cairns, Hewstone, & Hamberger, 2002). Second, although research suggests that intergroup contact in Northern Irish universities tends to be relatively cursory, consisting of casual rather than intimate contact, attending university undoubtedly increases most people's overall amount of contact and their opportunity for intimate contact with members of the other community (Cairns, Dunn, & Gallagher, 1993). Total residential desegregation, in fact, does not exist in Northern Ireland. Whyte (1991) estimated that "about 35 to 40 per cent of the population live in segregated neighbourhoods" (p. 34). This suggests that the level of contact experienced by the general population (and by students when living at home) is

highly affected by where they live. To ascertain whether these differences in intergroup experience would limit the external validity of Study 1's results, we carried out a second study using a representative sample drawn from the adult general population. Study 2 provided a substantial replication of Study 1. However, to simplify survey completion by respondents with a wide range of social and educational backgrounds, the wording and response formats of some of the items were modified and the number of items contained in multi-item scales was reduced. As a consequence, four of the five constructs included in the estimated model were measured in a slightly different manner. Finally, the comparison between direct and indirect outgroup friends was improved by measuring them on identical response scales.

Method

RESPONDENTS

Respondents were 735 adults who were randomly selected to be part of the representative sample for the Northern Ireland Omnibus survey and identified themselves as belonging to one of the two religious communities (Catholic community, 275; Protestant community, 460). Respondents comprised 320 men and 415 women; their mean age was 45.81 years ($SD = 18.42$). Data was collected during May 2000.

PROCEDURE

A sample of 2,050 addresses was drawn from the Valuation and Lands Agency list of private addresses. The complete list was stratified into three regions (Belfast, East Northern Ireland, and West Northern Ireland), and a random sample was drawn from each stratum. To convert the list of addresses into a list of respondents, 93 interviewers first called at each address issued in their assignment to identify the number of households and to list all individuals who were eligible for inclusion in the sample (all persons aged 16 or older living at the address

at that time). Thirty-four percent of households consisted of one adult, 45% consisted of two, 11% contained three, and 9% consisted of four or more adults. A selection table was used to select an individual household within multiple household addresses, and a computer was used to randomly select an individual respondent within multiple resident households. The selected respondents were then asked to complete the interview as part of a study conducted by the University of Ulster on Catholic and Protestant people and their families living in Northern Ireland. All interviews were conducted face-to-face, and cards with questions and response options were shown to respondents to supplement verbal statements.

QUESTIONNAIRE

Predictor variables. To assess direct cross-group friendship, respondents were asked to rate the number of friends they had who belonged to the other community; to assess indirect cross-group friendship, respondents were asked to rate the number of friends belonging to their own community who had friends from the other community (both items, 1 = *none*, 2 = *some*, 3 = *most*, 4 = *all*).² These two variables were linearly transformed to equate their metric to the metric of the other variables included in the model.

Mediator variable. Respondents were first invited to think about how they felt when meeting people from the other community and then to rate the extent to which they felt relaxed, awkward, at ease, and tense (all scales, 0 = *not at all*, 1 = *not usually*, 2 = *can't say/don't know*, 3 = *sometimes*, 4 = *always*). We created a reliable index ($\alpha = .85$) by first reversing the items "relaxed" and "at ease" and then averaging all items together; higher scores denote higher intergroup anxiety.

Criterion variables. Five items tapped prejudice toward the religious outgroup. Respondents were first asked to indicate the degree to which they would mind if a suitably qualified person of a different religion were appointed as their boss and if one of their close relatives were to marry a person of a different religion (both items, 1 = *don't mind*, 2 = *can't say/don't know*, 3 = *mind a little*, 4 = *mind a lot*). Respondents were then asked to indicate their degree of agreement with the statements, "Those from the other community get jobs that your community should have"; "Most politicians in Britain care too much about the other community and not enough about your community"; "Your community and the other community will never be really comfortable with each other, even if they are close friends" (0 = *disagree strongly*, 1 = *disagree somewhat*, 2 = *can't say/don't know*, 3 = *agree somewhat*, 4 = *agree strongly*). We linearly transformed the first two items to equate their metric to the remainder before forming an aggregate index ($\alpha = .69$);

higher scores denote higher prejudice. A single item tapped general perceived outgroup variability; respondents rated the extent to which, in the other community, there were many different types of people (0 = *disagree strongly*, 1 = *disagree somewhat*, 2 = *can't say/don't know*, 3 = *agree somewhat*, 4 = *agree strongly*).

Sociodemographic variables. Respondents' age and gender were already available at the time of the respondents' selection. As part of the interview, experience of The Troubles was assessed by asking whether the respondent had ever suffered directly as a result of The Troubles (*direct*, *yes*, *no*) and whether they had a relative or close friend in their community who had suffered as a result of The Troubles (*indirect*, *yes*, *no*). Religious affiliation was measured in the same way as in Study 1.

Results and Discussion

PRELIMINARY ANALYSES

Fifty-one percent of the overall sample reported at least some direct or indirect experience of The Troubles, confirming the widespread impact of the intergroup conflict on the Northern Irish population. More specifically, 22.30% reported having suffered directly and 48.60% reported having a relative or close friend who had suffered as a result of The Troubles. Respondents scored around the scale midpoint on the measures of direct friendship ($M = 1.73$, $SD = 1.01$, $Skew = .45$, $SE Skew = .09$, $Kurt = .02$, $SE Kurt = .18$) and indirect friendship ($M = 2.02$, $SD = 1.22$, $Skew = .48$, $Kurt = -.84$). They reported relatively low scores for intergroup anxiety ($M = .53$, $SD = .79$, $Skew = 1.63$, $Kurt = 2.30$) and prejudice ($M = 1.27$, $SD = .89$, $Skew = .78$, $Kurt = .17$) and relatively high scores for perceived outgroup variability ($M = 3.37$, $SD = .88$, $Skew = -1.77$, $Kurt = 3.26$).

Group comparisons. Table 3 contains the descriptives for all sociodemographic variables and variables included in the estimated model separately for Catholic and Protestant respondents. Subscripts identify significant differences between samples. Catholic respondents reported less prejudice toward the religious outgroup than did Protestant respondents, $p < .01$; this finding is consistent with a review of outgroup attitude studies in Northern Ireland (Whyte, 1991) reporting relatively more benevolent outgroup attitudes among Catholics.

STRUCTURAL EQUATION MODELING

The same causal model with latent variables tested in Study 1 was tested in Study 2.³ Due to the reduced number of items used in this study, the number of parcel variables employed in the partial disaggregation approach (Bagozzi & Heatherton, 1994) was two for intergroup anxiety and prejudice. Direct friendships, indirect friendships, and perceived outgroup variability were single-

TABLE 3: Descriptives of Sociodemographic Variables and Variables Included in the Model for Catholic and Protestant Respondents (Study 2)

Variable	Catholic (n = 275)	Protestant (n = 460)
Sociodemographic variables ^a		
Age		
M	42.76 _a	47.64 _b
SD	18.04 _a	18.42 _a
Male	43.3 _a	43.7 _a
Having suffered directly as a result of The Troubles	21.80 _a	22.60 _a
Relative or close friend having suffered as a result of The Troubles	49.80 _a	47.80 _a
Variables included in the model ^b		
Direct friendship		
M	1.78 _a	1.70 _b
SD	1.07	.97
Indirect friendship		
M	1.98 _a	2.04 _a
SD	1.21	1.22
Intergroup anxiety		
M	0.50 _a	0.55 _a
SD	0.74	0.82
Outgroup prejudice		
M	1.14 _a	1.35 _b
SD	0.72	0.97
Perceived outgroup variability		
M	3.40 _a	3.35 _a
SD	0.85	0.90

NOTE: Means and frequencies with different subscripts differ significantly at $p < .01$.

a. All sociodemographic indices, except for age (number of years), are percentages.

b. All indices included in the model range between 0 and 4.

item constructs. The estimated model is represented in the path diagram shown in Figure 2. The theoretical model provided good fit to the data, as indicated by the chi-square statistic, $\chi^2(7, N = 735) = 16.39, p > .02$; by the comparative fit index, CFI = .99; and by the summary statistics for residuals (RMSEA = .043, SRMR = .014). The model accounted for 16% of the variance in intergroup anxiety, for 40% of the variance in prejudice, and for 5% of the variance in perceived outgroup variability.

In this study, we expected to replicate the pattern of associations detected in the previous study. Consistent with these expectations, direct cross-group friendship had a direct effect on outgroup prejudice (standardized $\beta = -.29$, unstandardized $b = -.20, p < .001$) and affected perceived outgroup variability, but only indirectly, mediated by intergroup anxiety, which was negatively associated with perceived variability ($\beta = -.14, b = -.16, p < .001$). Again, indirect cross-group friendship significantly affected prejudice indirectly, mediated by intergroup anxiety, which was strongly associated with prejudice ($\beta = .39, b = .32, p < .001$) and had a direct effect on perceived

variability ($\beta = .15, b = .15, p < .001$). As in Study 1, we expected intergroup anxiety to function as a mediator of the effects exerted by both direct and indirect friendship on group judgments. Direct and indirect cross-group friendships were negatively related to intergroup anxiety ($\beta = -.24, b = -.20, p < .001$; $\beta = -.23, b = -.19, p < .001$, respectively). As in Study 1, the direct path linking direct friendship to variability was not reliable ($\beta = -.05, b = -.05, p > .05$); this confirms that the relationship between these two variables was fully mediated by intergroup anxiety. However, this time, with the increased power provided by the large sample, the direct path linking indirect friendship to prejudice, although again modest in size, also was reliable ($\beta = -.13, b = -.09, p < .01$). Hence, partial mediation of anxiety held for the relationship between direct friendship and prejudice, for the relationship between indirect friendship and variability, and this time for the relationship between indirect friendship and prejudice. A significant association was also found between the two outcome variables, $r = -.11, p < .01$.

EFFECTS DECOMPOSITION

A summary of this analysis is shown in Table 4. As in Study 1, the total effect of direct cross-group friendship on prejudice (TE = $-.38, p < .001$) seemed greater than that of indirect friendship (TE = $-.22, p < .001$). Unlike in Study 2, however, the picture was reversed for perceived outgroup variability; the total effect of indirect friendship (TE = $.18, p < .001$) seemed greater than the total effect of direct friendship (TE = $-.01, ns$). Once again, however, the indirect effect that each predictor variable exerted on each of the criterion variables, although not large in size, was also significant (direct friendship-to-prejudice, IE = $-.09, p < .001$; direct friendship-to-variability, IE = $.03, p < .01$; indirect friendship-to-prejudice, IE = $-.09, p < .001$; indirect friendship-to-variability, IE = $.03, p < .01$). These results confirm that each type of cross-group friendship predicted each type of group judgment and that intergroup anxiety had a mediating role to play within both the direct and indirect friendship-to-group relationships. Hence, although in Study 2 the association between variables was generally slightly weaker than in Study 1, there appeared to be fairly good replication of the previous study's results.

GENERAL DISCUSSION

We expected direct cross-group friendship (Pettigrew, 1997) and indirect cross-group friendship (Wright et al., 1997) to predict, for both Catholic and Protestant respondents, more benevolent judgments of the rival community, that is, reduced prejudice and increased perceived outgroup variability. Furthermore, we expected an anxiety-reduction mechanism to pro-

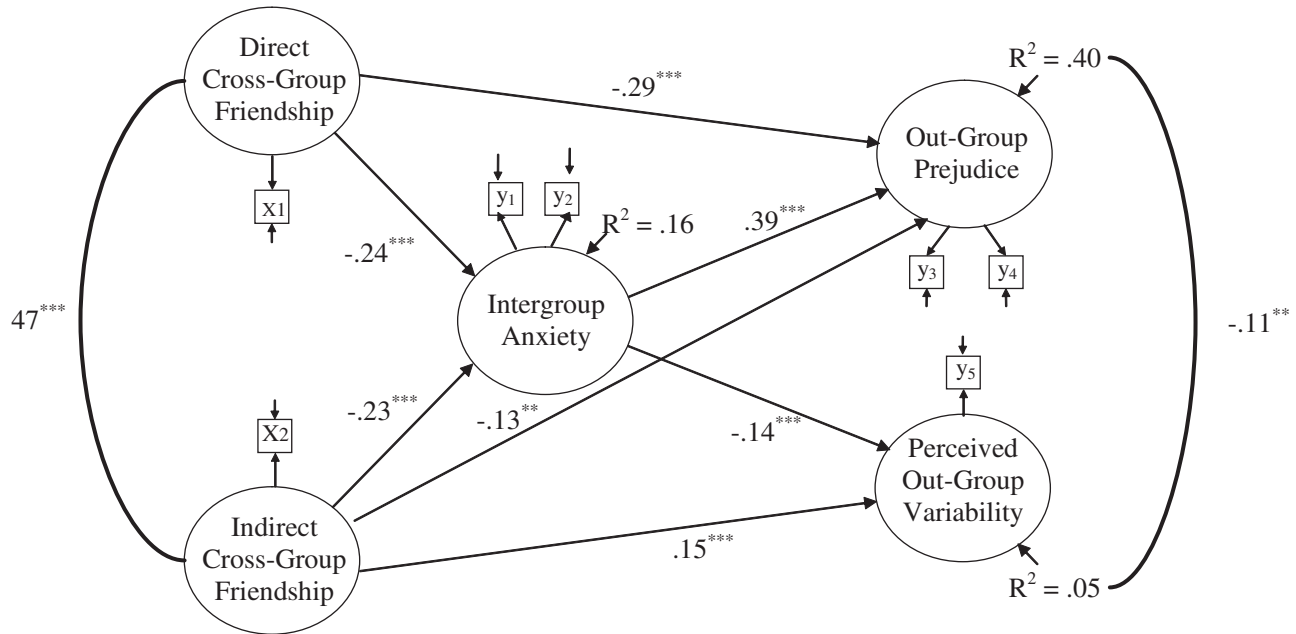

Figure 2 Estimated model of direct and indirect cross-group friendship for representative adult sample in Study 2.
 NOTE: Values are standardized beta weights. $\chi^2(7, N = 735) = 16.39, p > .02$, Comparative Fit Index (CFI) = .99, root mean square error of approximation (RMSEA) = .043, standardized root mean square residual (SRMR) = .014.
 ** $p < .01$. *** $p < .001$.

TABLE 4: Intercorrelations for All Variables and Effects Decomposition (Study 2)

Bivariate Relationship		Total Correlation	Causal Effects		
Predictor	Criterion		DE	IE	TE
Direct friendship	Intergroup anxiety	-.33***	-.24*** (-.20)	—	-.24*** (-.20)
Indirect friendship	Intergroup anxiety	-.33***	-.23*** (-.20)	—	-.23*** (-.20)
Direct friendship	Outgroup prejudice	-.43***	-.29*** (-.20)	-.09*** (-.06)	-.38*** (-.27)
Indirect friendship	Outgroup prejudice	-.34***	-.13** (-.09)	-.09*** (-.06)	-.22*** (-.15)
Intergroup anxiety	Outgroup prejudice	.44***	.39*** (.32)	—	.39*** (.32)
Direct friendship	Perceived variability	.07*	-.05 (-.05)	.03** (.03)	-.01 (-.01)
Indirect friendship	Perceived variability	.18***	.15*** (.15)	.03** (.03)	.18*** (.18)
Intergroup anxiety	Perceived variability	-.17***	-.14*** (-.16)	—	-.14*** (-.16)

NOTE: $N = 735$. DE = direct effect; IE = indirect effect; TE = total effect. Unstandardized effects are in parentheses.
 * $p < .05$. ** $p < .01$. *** $p < .001$.

vide a common explanatory basis for both the direct and the indirect cross-group friendship effects (see also Wright et al., 1997). These two predictions received empirical support in latent variable models tested using cross-sectional data from a convenience sample of students (Study 1) and from a representative sample of the adult population (Study 2) in Northern Ireland.

In both samples, direct and indirect cross-group friendship significantly predicted weaker prejudice toward the rival community and greater perceived outgroup variability. These effects remained significant, although not large in magnitude, even when the other type of cross-group friendship was controlled for. Wright

and colleagues (1997) believe that the identification of a unique contribution of indirect friendship over and above the contribution of direct friendship (see, e.g., Wright et al., 1997; cf. Liebkind & McAlister, 1999) helps to ascertain the direction of causality in the friendship-prejudice relationship. They argue that it reflects the beneficial causal effect of increased friendship on debiased group judgments rather than the causal effect of prejudiced group responding on friendship avoidance. More specifically, it is argued that being less prejudiced toward an outgroup would more easily translate into one's having more friends in the outgroup (i.e., we do choose our own friends) than in having more

ingroup friends who have outgroup friends (i.e., we do not choose whom our ingroup friends choose as their friends). Hence, finding a significant effect of indirect friendship on group judgments, partialing out the effect of direct friendship, would increase our confidence that friendship causes prejudice and not vice versa.

The finding of a beneficial effect of cross-group friendship on perceived outgroup variability is new in the cross-group friendship literature. Although the amount of variance accounted for in this new outcome variable was smaller than we had hoped, possibly because of our limited measure of the construct (three items in Study 1, a single item in Study 2) and seemed to reflect more the impact of indirect than direct friendship, these results still suggest that the desirable effects of cross-group friendship on intergroup relations might extend beyond those already documented on prejudice and affect-based outcomes of contact. By increasing perceived outgroup variability, cross-group friendship might, in fact, have the potential to improve future intergroup encounters between members of rival communities. It could achieve this by various mechanisms: decreasing the confidence with which stereotypical outgroup judgments are made (Ryan et al., 1996), making it less likely that disconfirming outgroup members would be “fenced off” as atypical group exemplars (Lambert, 1987), and reducing active search for (Ryan et al., 2000) and recall advantage (Pendry & Macrae, 1999) of stereotype-congruent information. More generally, our results encourage cross-group friendship researchers to include a broader variety of both group judgments and contact-related outcome variables in their studies (Paolini et al., in press).

Finally, because cross-group friendship provides examples of successful and pleasant interactions with outgroup members, we expected it to ameliorate outgroup judgments by means of reducing intergroup anxiety. Consistent with these predictions, structural equation modeling with both student and adult samples confirmed that having a close friend in the outgroup, or having an ingroup friend who has an outgroup friend, would both reduce prejudice and increase perceived outgroup variability (at least partly) by decreasing the anxiety associated with intergroup encounters. This pattern of results is in line with a well-documented arousal-reduction effect of friendship (Ashton et al., 1980; La Greca & Lopez, 1998; Matsuzaki et al., 1993; Prinstein et al., 2000).

Limitations of the Present Research

First, these data are only correlational and clearly need to be backed up by both more controlled and extensive experimental evidence and longitudinal results. Second, a single, fixed order of measures

(predictor-mediator-criterion) was used, which may have artificially inflated the size of the bivariate relationships. However, this order has been varied in other research and had no impact (see Harwood, Hewstone, Paolini, & Voci, 2002). A further limitation of this research may lie in our measures of intergroup anxiety: Stephan and Stephan's (1984) intergroup anxiety scale in Study 1 and a simplified version of this scale in Study 2. These self-report measures of anxiety are surely reactive compared, for example, with electrophysiological or cardiovascular measures of arousal. Moreover, they also appear relatively a-contextual in nature. As a consequence, rather than tapping conditioned and uncontrolled emotional reactions toward members of the rival community, they may capture differences in memory-mediated effects of cross-group friendship experiences. Thus, people who have a larger number of friends may be more likely to recall friendly situations when filling in the anxiety measure than people who have a smaller number of friends, hence artificially inflating the association between friendship and anxiety. Despite these potential methodological limitations, we still believe that our results have provocative implications, specifically, for interventions based on intergroup contact in Northern Ireland and, generally, for future research on generalized outgroup attitudes.

Implications of the Present Research

PROMOTING CONTACT IN NORTHERN IRELAND

These cross-group friendship results, especially those regarding the effect of indirect friendship, have important policy implications for interventions aimed at improving intergroup relations in Northern Ireland. One of the most radical attempts to combat segregation has involved the development of planned integrated schools with approximately equal numbers of Catholic and Protestant pupils, teachers, and school governors (A. Smith, 1995). Unfortunately, almost 20 years since the start of the integrated school movement, the integrated education sector still only caters to less than 10% of the school population in Northern Ireland (Frazer & Fitzduff, 1986). Critics have suggested that because of its modest size, integrated education is unlikely to have a major impact on Northern Irish intergroup relations. Against this pessimistic claim, the present research encourages the maintenance and establishment of similar settings of intergroup contact. First, with the direct friendship findings, it reinforces hope in the potential of direct contact between children of rival communities. Moreover, with the indirect friendship findings, it raises the possibility that integrated education may be affecting intergroup relations on a wider scale than its absolute numbers would suggest, via a “ripple” effect,

and should therefore be encouraged as one of many routes to more harmonious intergroup relations.

INTEGRATING COGNITION AND AFFECT

Stephan and Stephan (1985) considered intergroup anxiety to be a fundamental intermediate variable between experiences of intergroup contact and their behavioral, cognitive, and affective consequences. These studies, together with previous correlational data (Islam & Hewstone, 1993; Stephan & Stephan, 2000), seem to provide strong support for this view. In the present research, cross-group friendship predicted low intergroup anxiety (Stephan & Stephan, 1984); furthermore, the good fit of the estimated models, together with the significance of the indirect effects, confirmed the crucial mediating role of intergroup anxiety. These findings have important things to say about the way in which researchers have generally approached the issue of contact generalization in the past and about the way they need to approach it in the future.

Social cognition has offered great insight into the cognitive foundations of social judgments (Schwarz, 2000). An identical cognitive emphasis has appeared in and dominated the stereotype change research (Johnston & Hewstone, 1990), as evidenced by the use of controlled paradigms (Wilder, 1993), the choice of outcome measures, and the type of mediators tested in generalization research (Paolini, 2001). The central role of intergroup anxiety in the process of friend-to-group generalization underlines that a purely cognitive analysis of generalization and contact is incomplete (Pettigrew, 1998; Wilder, 1993). Once again, it suggests that contact can have an impact on affect as much as on cognition (Batson et al., 1997; Pettigrew, 1998) and that affect-based strategies of generalization (e.g., empathy), besides cognitive strategies of generalization (e.g., typicality), have the potential to enrich the repertoire of tools used to ameliorate intergroup judgments (Batson et al., 1997).

INTEGRATING INTERPERSONAL AND INTERGROUP APPROACHES

Researchers have emphasized only very recently the potential benefits for intergroup relations of a fundamental and natural form of social interaction such as friendship (Pettigrew, 1997; Wright et al., 1997). This might be due to (a) a culturally biased association between friendship and interpersonal, rather than intergroup, relationships (Pettigrew, 1986) combined with (b) a static and rigid dichotomization between interpersonal and intergroup contact settings (Brewer & Miller, 1984; Brown & Turner, 1981; Hewstone & Brown, 1986).

Close friendship has often, and by definition, been conceived by lay people and scientists as founded exclusively on individual traits and on information relevant to the definition of the personal self (see, e.g., Hogg &

Hains, 1998; Leichthy, 1989). As a consequence, researchers who combined these cultural premises with skepticism regarding generalization from interpersonal to intergroup settings expressed little confidence that cross-group friendships could help to ameliorate intergroup judgments (see, e.g., Pettigrew, 1986; Taylor, Dubé, & Bellerose, 1986; Trew, 1986). For example, Bellerose, Hafer, and Taylor (1984, cited in Taylor et al., 1986) expected that sensitive intergroup issues, such as Quebec politics, would be strictly avoided as a topic of conversation between friends belonging to the Anglophone and to the Francophone communities in Quebec. These researchers expressed surprise when they found that Anglophone respondents claimed to discuss sensitive intergroup issues more with outgroup friends than with ingroup friends. Bellerose et al.'s results, though, clearly demonstrate that friendship between members of different social groups is more than a purely interpersonal experience. Close friendship is a rich and temporally extended experience in which both interpersonal and intergroup qualities of encounters can dynamically coexist and be integrated. Hence, one can be intimate with an outgroup member without necessarily forgetting mutual group memberships. Both Pettigrew (1997) and Wright et al. (1997) have acknowledged this complexity and this multiple-level nature of the reality of cross-group friendships. Their hypotheses suggest the need to bring together, in low-impact situations, positive experiences of outgroup members (the interpersonal element) and adequate levels of category salience (the intergroup element; see Voci & Hewstone, 2003).

By integrating interpersonal and intergroup approaches, these emerging hypotheses of generalization eventually challenge static and dichotomous conceptualizations of the interpersonal-intergroup distinction and perhaps partly reconcile enduring controversies (Wright et al., 1997). Brown and Turner (1981; Tajfel & Turner, 1979; Turner, Hogg, Oakes, Reicher, & Wetherell, 1987) proposed a sharp distinction between interpersonal and intergroup levels of investigation and, more importantly, questioned the generalization of effects across levels. A number of theorists have, however, attempted to reconceptualize the interpersonal-intergroup distinction from being two poles of the same continuum to being two independent dimensions (Deschamps & Devos, 1998; Hogg & Abrams, 1988; Serino, 1998; Simon, 1993; Stephenson, 1981). We believe that the construct of cross-group friendship is consistent with this latter theorizing and that two individuals, engaged in intergroup contact, can enjoy an interpersonal relationship while also, at minimum, being aware of their respective group memberships.

CONCLUSIONS

Trew (1986) concluded an early overview of contact studies in Northern Ireland as follows: "Religious denomination is not a barrier to personal friendship. However, the influence of such relationships on social understanding and beliefs about the other group has *not* been established" (p. 102, emphasis added). About twenty years later, the present research helps us to conclude that (a) personal friendship can help to reduce prejudice and increase perceived outgroup variability even when contact takes place against a background of intergroup conflict, as is the case for cross-community relations in Northern Ireland and that (b) such an influence is partly mediated by an anxiety-reduction mechanism. Hence, having friends among outgroup members and knowing ingroup friends who have outgroup friends can contribute positively to improved intergroup relations by virtue of reducing the anxiety associated with intergroup encounters.

Notwithstanding these optimistic findings and these hopes for the future of Northern Ireland, it must be pointed out that having outgroup friends is not, unfortunately, a panacea for prejudice or a vaccination against conflict. In some conflicts, the most shocking instances of members of one group massacring members of another group (e.g., former Yugoslavia, Rwanda) actually include particularly tragic cases of perpetrators betraying or killing former friends who happen to belong to the other group (see Agger, 2001; Peterson, 2000). Even though friendship contacts may prove an insufficient bulwark against norms of outgroup segregation or aggression, we still maintain that contact as friends is a powerful antidote to intergroup bias in many other cases.

NOTES

1. In both studies, we asked a number of additional questions about intergroup relations between Catholics and Protestants and the extent of forgiveness between the groups for past acts. To maintain the focus on the cross-group friendship hypotheses and their mediation, and to keep this paper of manageable size and complexity, we have not included analysis of these other variables in this article; we plan to publish the data excluded from this article in different articles on other aspects of sectarian conflict in Northern Ireland.

2. We interpreted the missing values ($n = 56$) along the open-ended measure of indirect friendship in Study 1 as reflecting the cognitive difficulty of this response format. Hence, in Study 2, we opted for a short and simple Likert-type scale measure of indirect friendship to facilitate the completion of this measure by members of the general population.

3. An alternative causal model could be proposed based on the idea that changes in group variability could "unfreeze" changes in prejudice (Hewstone & Hamberger, 2000; Lewin, 1948). To assess this idea, with both samples, we also tested a model in which anxiety and group variability were mediators of the effects of cross-group friendship on prejudice. These models had identical goodness of fit and coefficient strength to our principal models. The new directional path connecting variability to prejudice was, however, significant only for the representative sample, $\beta = -.12$, $b = -.08$, $p < .01$, and not for the student sample, $\beta = -.05$, $b = -.05$, $p > .05$.

REFERENCES

- Agger, I. (2001). Psychosocial assistance during ethnopolitical warfare in the former Yugoslavia. In D. Chirot & M. E. P. Seligman (Eds.), *Ethnopolitical warfare: Causes, consequences, and possible solutions* (pp. 305-318). Washington, DC: American Psychological Association.
- Allport, G. W. (1954). *The nature of prejudice*. Reading, MA: Addison-Wesley.
- Amir, Y. (1976). The role of intergroup contact in change of prejudice and race relations. In P. A. Katz (Ed.), *Towards the elimination of racism* (pp. 245-280). New York: Pergamon.
- Ashton, N. L., Shaw, M. E., & Worsham, A. P. (1980). Affective reactions to interpersonal distance by friends and strangers. *Bulletin of the Psychonomic Society*, *15*, 306-308.
- Bagozzi, R. P., & Heatherton, T. F. (1994). A general approach to representing multifaceted personality constructs: Application to state self-esteem. *Structural Equation Modeling*, *1*, 35-67.
- Batson, C. D., Polycarpou, P., Harmon-Jones, E., Imhoff, H. J., Mitchener, E. C., Bednar, L. L., et al. (1997). Empathy and attitudes: Can feelings for a member of a stigmatised group improve feelings toward the group? *Journal of Personality and Social Psychology*, *72*, 105-118.
- Brewer, M. B., & Miller, N. (1984). Beyond the contact hypothesis: Theoretical perspectives on desegregation. In N. Miller & M. Brewer (Eds.), *Groups in contact: The psychology of desegregation* (pp. 281-302). New York: Academic Press.
- Brewer, M. B., & Miller, N. (1988). Contact and cooperation: When do they work? In P. Katz & D. Taylor (Eds.), *Eliminating racism: Profiles in controversy* (pp. 315-326). New York: Plenum.
- Brown, R., & Turner, J. C. (1981). Interpersonal and intergroup behavior. In J. C. Turner & H. Giles (Eds.), *Intergroup behavior* (pp. 33-65). Chicago: University of Chicago Press.
- Brown, R., Vivian, J., & Hewstone, M. (1999). Changing attitudes through intergroup contact: The effects of group membership salience. *European Journal of Social Psychology*, *29*, 741-764.
- Cairns, E., & Darby, J. (1998). The conflict in Northern Ireland: Causes, consequences, and controls. *American Psychologist*, *53*, 754-760.
- Cairns, E., Dunn, S., & Gallagher, A. (1993). *Intergroup contact in a Northern Irish university setting: A report to the Central Community Relations Unit*. Coleraine, Northern Ireland: Centre for the Study of Conflict.
- Cairns, E., & Hewstone, M. (in press). Northern Ireland: The impact of peacemaking on intergroup behaviour. In G. Salomon & B. Neov (Eds.), *Peace education: The concept, principles, and practices around the world*. Mahwah, NJ: Lawrence Erlbaum.
- Cairns, E., Hewstone, M., & Hamberger, H. (2002). *Determinants of attitudes to intergroup contact in Northern Ireland*. Unpublished manuscript, University of Ulster, United Kingdom.
- Carmine, E., & McIver, J. (1981). Analyzing models with unobserved variables: Analysis of covariance structures. In G. Bohrnstedt & E. Borgatta (Eds.), *Social measurement*. Beverly Hills, CA: Sage.
- Cohen, S., Sherrod, D. R., & Clark, M. S. (1986). Social skills and the stress-protective role of social support. *Journal of Personality and Social Psychology*, *50*, 963-973.
- Deschamps, J.-C., & Devos, T. (1998). Regarding the relationship between social identity and personal identity. In S. Worchel, J. F. Morales, D. Paez, & J.-C. Deschamps (Eds.), *Social identity: International perspectives* (pp. 1-12). London: Sage Ltd.
- DuBois, D., & Hirsch, B. (1990). School and neighbourhood friendship patterns of Blacks and Whites in early adolescence. *Child Development*, *61*, 524-536.
- Eastbrook, J. A. (1959). The effect of emotion on cue utilization and the organization of behavior. *Psychological Review*, *66*, 183-201.
- Ellison, C. G., & Powers, D. A. (1994). The contact hypothesis and racial attitudes among Black Americans. *Social Science Quarterly*, *75*, 385-400.
- Frazer, H., & Fitzduff, M. (1986). *Improving community relations*. Paper prepared for the Standing Advisory Commission on Human Rights, Belfast, United Kingdom.

- Gaertner, S. L., & Dovidio, J. F. (2000). *Reducing intergroup bias: The common ingroup identity model*. Philadelphia: Psychology Press.
- Gaertner, S. L., Dovidio, J. F., Anastasio, P. A., Bachman, B. A., & Rust, M. C. (1993). The common ingroup identity model: Recategorization and the reduction of intergroup bias. In W. Stroebe & M. Hewstone (Eds.), *European review of social psychology* (Vol. 4, pp. 1-26). Chichester, UK: Wiley & Sons, Ltd.
- Garcia-Marques, L., & Mackie, D. M. (1999). The impact of stereotype incongruent information on perceived group variability and stereotype change. *Journal of Personality and Social Psychology*, *77*, 979-990.
- Haddock, G., Zanna, M. P., & Esses, V. M. (1993). Assessing the structure of prejudicial attitudes: The case of attitudes toward homosexuals. *Journal of Personality and Social Psychology*, *65*, 1105-1118.
- Hallinan, M. T. (1982). Classroom racial composition and children's friendships. *Social Forces*, *61*, 56-72.
- Hallinan, M. T., & Teixeira, R. A. (1987). Students' interracial friendships: Individual characteristics, structural effects and racial differences. *American Journal of Education*, *95*, 563-583.
- Hamberger, J., & Hewstone, M. (1997). Inter-ethnic contact as a predictor of blatant and subtle prejudice: Tests of a model in four West European nations. *British Journal of Social Psychology*, *36*, 173-190.
- Hamilton, D. L., & Bishop, G. D. (1976). Attitudinal and behavioral effects of initial integration of White suburban neighborhoods. *Journal of Social Issues*, *32*, 47-67.
- Harwood, J., Hewstone, H., Paolini, S., & Voci, R. (2002). *Intergroup contact theory, the grandparent-grandchild relationship, and attitudes towards older adults*. Manuscript submitted for publication.
- Haslam, S. A., McGarty, C., & Turner, J. C. (1996). Salient group membership and persuasion: The role of social identity in the validation of beliefs. In J. L. Nye & A. M. Brown (Eds.), *What is social about social cognition? Research on socially shared cognition in small groups* (pp. 29-56). Thousand Oaks, CA: Sage.
- Hayes, P., & Campbell, J. (2000). Dealing with post-traumatic stress disorder: The psychological sequelae of Bloody Sunday and the response of state service. *Research on Social Work Practice*, *10*, 705-720.
- Hayes, B. C., & McAllister, I. (2002). Sowing dragon's teeth: Public support for political violence and paramilitarism in Northern Ireland. *Political Studies*, *49*, 901-922.
- Herek, G. M., & Capitanio, J. P. (1996). "Some of my best friends": Intergroup contact, concealable stigma, and heterosexuals' attitudes toward gay men and lesbians. *Personality and Social Psychological Bulletin*, *22*, 412-424.
- Hewstone, M. (1996). Contact and categorization: Social psychological interventions to change intergroup relations. In C. N. Macrae, C. Stangor, & M. Hewstone (Eds.), *Stereotypes and stereotyping* (pp. 323-368). New York: Guilford.
- Hewstone, M., & Brown, R. (1986). Contact is not enough: An intergroup perspective on the "contact hypothesis." In M. Hewstone & R. Brown (Eds.), *Contact and conflict in intergroup encounters* (pp. 1-44). Oxford, UK: Blackwell.
- Hewstone, M., Cairns, E., Voci, A., Paolini, S., McLernon, F., Crisp, R. J., et al. (in press). Intergroup contact in a divided society: Challenging segregation in Northern Ireland. To appear in D. Abrams, J. M. Marques, & M. A. Hogg (Eds.), *The social psychology of inclusion and exclusion*. Philadelphia: Psychology Press.
- Hewstone, M., & Hamberger, J. (2000). Perceived variability and stereotype change. *Journal of Experimental Social Psychology*, *36*, 103-124.
- Hogg, M. A., & Abrams, D. (1988). *Social identifications: A social psychology of intergroup relations and group processes*. London: Routledge.
- Hogg, M. A., & Hains, S. C. (1998). Friendship and group identification: A new look at the role of cohesiveness in groupthink. *European Journal of Social Psychology*, *28*, 323-341.
- Hoyle, R. H. (1995). *Structural equation modeling: Concepts, issues, and applications*. Thousand Oaks, CA: Sage.
- Hu, L.-T., & Bentler, P. M. (1999). Cut-off criteria for fit indexes in covariance structure analysis: Conventional criteria versus new alternatives. *Structural Equation Modeling*, *6*, 1-55.
- Islam, M. R., & Hewstone, M. (1993). Dimensions of contact as predictors of intergroup anxiety, perceived outgroup variability, and outgroup attitude: An integrative model. *Personality and Social Psychological Bulletin*, *19*, 700-710.
- Jackman, M. R., & Crane, M. (1986). "Some of my best friends are Black . . .": Interracial friendships and Whites' racial attitudes. *Public Opinion Quarterly*, *50*, 459-486.
- Jackson, A. (1999). *Ireland: 1798-1998*. Oxford, UK: Blackwell.
- Johnston, L., & Hewstone, M. (1990). Intergroup contact: Social identity and social cognition. In D. Abrams & M. Hogg (Eds.), *Social identity theory: Constructive and critical advances* (pp. 185-210). London: Harvester Wheatsheaf.
- Jöreskog, K. J., & Sörbom, D. (1999). LISREL 8.3: Interactive LISREL [Computer software]. Chicago: Scientific Software International.
- Kashima, E. S., & Kashima, Y. (1993). Perceptions of general variability of social groups. *Social Cognition*, *11*, 1-21.
- Kraus, S., Ryan, C. S., Judd, C. M., Hastie, R., & Park, B. (1993). Use of mental frequency distributions to represent variability among members of social categories. *Social Cognition*, *11*, 22-43.
- La Greca, A., & Lopez, N. (1998). Social anxiety among adolescents: Linkages with peer relations and friendships. *Journal of Abnormal Child Psychology*, *26*, 83-94.
- Lambert, A. J. (1987). Stereotypes and social judgement: The consequences of group variability. *Journal of Personality and Social Psychology*, *68*, 388-403.
- Leichty, G. (1989). Interpersonal constructs and friendship form and structure. *Interpersonal Journal of Personal Construct Psychology*, *2*, 401-415.
- Lewin, K. (1948). *Resolving social conflict*. New York: Harper.
- Liebkind, K., & McAlister, A. L. (1999). Extended contact through peer modeling to promote tolerance in Finland. *European Journal of Social Psychology*, *29*, 765-780.
- Linville, P. W. (1998). The heterogeneity of homogeneity. In J. M. Darley & J. Cooper (Eds.), *Attribution and social interaction: The legacy of Edward E. Jones* (pp. 423-487). Washington, DC: American Psychological Association.
- Loehlin, J. C. (1998). *Latent variable models: An introduction to factor, path, and structural analysis* (3rd ed.). Mahwah, NJ: Lawrence Erlbaum.
- Matsuzaki, M., Kojo, K., & Tanaka, K. (1993). The effects of social support from friends on anxiety and task performance. *Journal of Applied Biobehavioral Research*, *1*, 101-119.
- Muldoon, O. T., & Trew, K. (2000). Children's experience and adjustment to political conflict in Northern Ireland. *Peace and Conflict: Journal of Peace Psychology*, *6*, 157-176.
- Oliner, S. P., & Oliner, P. M. (1988). *The altruistic personality: Rescuers of Jews in Nazi Europe*. New York: Free Press.
- Paolini, S. (2001). *Member-to-group generalization: Moderators, mediators, and social consequences*. Unpublished doctoral dissertation, University of Cardiff, United Kingdom.
- Paolini, S., Hewstone, M., Rubin, M., & Pay, H. (in press). Increased group dispersion after exposure to one deviant group member: Testing Hamberger's model of member-to-group generalization. *Journal of Experimental Social Psychology*.
- Patchen, M. (1983). Students' own racial attitudes and those of peers of both races, as related to interracial behavior. *Sociology and Social Research*, *68*, 59-77.
- Pendry, L. F., & Macrae, C. N. (1999). Cognitive load and person memory: The role of perceived group variability. *European Journal of Social Psychology*, *29*, 925-942.
- Peterson, S. (2000). *Me against my brother: At war in Somalia, Sudan, and Rwanda*. New York: Routledge.
- Pettigrew, T. F. (1986). The intergroup contact hypothesis reconsidered. In M. Hewstone & R. Brown (Eds.), *Contact and conflict in intergroup encounters* (pp. 169-195). Oxford, UK: Blackwell.
- Pettigrew, T. F. (1997). Generalized intergroup contact effects on prejudice. *Personality and Social Psychological Bulletin*, *23*, 173-185.
- Pettigrew, T. F. (1998). Intergroup contact theory. *Annual Review of Psychology*, *49*, 65-85.
- Pettigrew, T. F., Jackson, J., Ben Brika, J., Lemaine, G., Meertens, R. W., Wagner, U., et al. (1998). Outgroup prejudice in Western Europe. *European Review of Social Psychology*, *8*, 241-273.

- Phinney, J. S., Ferguson, D. L., & Tate, J. D. (1997). Intergroup attitudes among ethnic minority adolescents: A causal model. *Child Development, 68*, 955-969.
- Pickett, C. L., & Brewer, M. B. (2001). Assimilation and differentiation needs as motivational determinants of perceived ingroup and outgroup homogeneity. *Journal of Experimental Social Psychology, 37*, 341-348.
- Prinstein, M., Boergers, J., Spirito, A., Little, T. D., & Grapentine, W. L. (2000). Peer functioning, family dysfunction, and psychological symptoms in a risk factor model for adolescent inpatients' suicidal ideation severity. *Journal of Clinical Child Psychology, 29*, 392-405.
- Rothbart, M., & John, O. P. (1985). Social categorization and behavioral episodes: A cognitive analysis of the effect of intergroup contact. *Journal of Social Issues, 41*, 81-104.
- Rubin, M., Hewstone, M., & Voci, A. (2001). Stretching the boundaries: Strategic perceptions of intragroup variability. *European Journal of Social Psychology, 31*, 413-429.
- Ryan, C. S., Bogart, L. M., & Vender, J. P. (2000). Effects of perceived group variability on the gathering of information about individual group members. *Journal of Experimental Social Psychology, 36*, 90-101.
- Ryan, C. S., Judd, C. M., & Park, B. (1996). Effects of racial stereotypes on judgments of individuals: The moderating role of perceived group variability. *Journal of Experimental Social Psychology, 32*, 71-103.
- Scarberry, N. C., Ratcliff, C. D., Lord, C. G., Lanicek, D. L., & Desforges, D. M. (1997). Effects of individuating information on the generalization part of Allport's contact hypothesis. *Personality and Social Psychological Bulletin, 23*, 1291-1299.
- Schwarz, N. (2000). Social judgment and attitudes: Warmer, more social, and less conscious. *European Journal of Social Psychology, 30*, 149-176.
- Serino, C. (1998). The personal-social interplay: Social-cognitive prospects on identity and self-others comparison. In S. Worchel, J. F. Morales, D. Paez, & J.-C. Deschamps (Eds.), *Social identity: International perspectives* (pp. 24-43). London: Sage.
- Sherif, M. (1966). *Group conflict and cooperation: Their social psychology*. London: Routledge Kegan Paul.
- Simon, B. (1993). On the asymmetry in the cognitive construal of ingroup and outgroup: A model of egocentric social categorization. *European Journal of Social Psychology, 23*, 131-147.
- Smith, A. (1995). Education and the conflict in Northern Ireland. In S. Dunn (Ed.), *Facets of the conflict in Northern Ireland* (pp. 168-186). New York: St. Martin's.
- Smith, E. R., & Henry, S. (1996). An ingroup becomes part of the self: Response-time evaluation. *Personality and Social Psychological Bulletin, 22*, 635-642.
- Stangor, C., Jonas, K., Stroebe, W., & Hewstone, M. (1996). Influence of student exchange on national stereotypes, attitudes and perceived variability. *European Journal of Social Psychology, 26*, 663-675.
- Stephan, W. G., & Stephan, C. W. (1984). The role of ignorance in intergroup relations. In N. Miller & M. R. Brewer (Eds.), *Groups in contact: The psychology of desegregation* (pp. 229-255). New York: Academic Press.
- Stephan, W. G., & Stephan, C. W. (1985). Intergroup anxiety. *Journal of Social Issues, 41*, 157-175.
- Stephan, W. G., & Stephan, C. W. (2000). An integrated threat theory of prejudice. In S. Oskam (Ed.), *Reducing prejudice and discrimination: The Claremont symposium on applied social psychology* (pp. 23-45). Mahwah, NJ: Lawrence Erlbaum.
- Stephenson, G. M. (1981). Intergroup bargaining and negotiation. In J. C. Turner & H. Giles (Eds.), *Intergroup behavior* (pp. 168-198). Chicago: University of Chicago Press.
- Tajfel, H., & Turner, J. C. (1979). An integrative theory of social conflict. In W. Austin & S. Worchel (Eds.), *The social psychology of intergroup relations* (pp. 33-47). Monterey, CA: Brooks/Cole.
- Taylor, D. M., Dubé, L., & Bellerose, J. (1986). Intergroup contact in Quebec. In M. Hewstone & R. Brown (Eds.), *Contact and conflict in intergroup encounters* (pp. 107-118). Oxford, UK: Blackwell.
- Trew, K. (1986). Catholic-Protestant contact in Northern Ireland. In M. Hewstone & R. Brown (Eds.), *Contact and conflict in intergroup encounters* (pp. 93-106). Oxford, UK: Blackwell.
- Turner, J. C., Hogg, M. A., Oakes, P. J., Reicher, S. D., & Wetherell, M. S. (1987). *Rediscovering the social group: A self-categorization theory*. New York: Basil Blackwell.
- Van Oudenhoven, J. P., Groenewoud, J. T., & Hewstone, M. (1996). Cooperation, ethnic salience and generalization of interethnic attitudes. *European Journal of Social Psychology, 26*, 649-661.
- Voci, A., & Hewstone, M. (2003). Intergroup contact and prejudice towards immigrants in Italy: the mediational role of anxiety and the moderational role of group salience. *Group Processes and Intergroup Relations, 6*, 37-54.
- Whyte, J. (1991). *Interpreting Northern Ireland*. Oxford, UK: Clarendon.
- Wilder, D. A. (1993). Freezing intergroup evaluations: Anxiety fosters resistance to counterstereotypic information. In M. Hogg & D. Abrams (Eds.), *Group motivation: Social psychological perspectives* (pp. 68-86). London: Harvester Wheatsheaf.
- Wright, S. C., Aron, A., McLaughlin-Volpe, T., & Ropp, S. A. (1997). The extended contact effect: Knowledge of cross-group friendships and prejudice. *Journal of Personality and Social Psychology, 73*, 73-90.

Received October 23, 2002

Revision accepted July 4, 2003